

# cooking collection

---

Instructions for use and warranty details

Warming Drawer

Model No.: WD14010 and WD27010

 **kLEENmaid**



## Congratulations on the purchase of your new Kleenmaid appliance.

---

Your new Kleenmaid appliance has been designed and manufactured to give you years of reliable performance.

For best results, carefully read the instructions on how to install your new appliance. Correct installation will avoid delays and unnecessary service call costs.

Once installation is complete, please read this entire instruction manual carefully and get to know the controls and the features of your new Kleenmaid appliance.

Again, congratulations and thank you for choosing Kleenmaid.



**Dear Customer,**

we would like to thank you and congratulate you on your choice.

This new product has been carefully designed and built using top quality materials, and meticulously tested to ensure that it meets all your culinary requirements.

Please read and observe these simple instructions, which will enable you to achieve excellent results from the very first time you use it. This state-of-the-art appliance comes to you with our very best wishes.

**THE MANUFACTURER**

**THIS PRODUCT IS DESIGNED FOR DOMESTIC USE. THIS APPLIANCE IS INTENDED FOR DOMESTIC AND SIMILAR USE, SUCH AS:**

- IN THE STAFF KITCHEN AREAS OF STORES, OFFICES AND OTHER WORKPLACES;
- IN FARMHOUSES;
- FOR USE BY HOTEL AND MOTEL GUESTS AND OTHER PROFESSIONAL ENVIRONMENTS;
- IN BED-AND-BREAKFASTS.

**THE MANUFACTURER DECLINES ALL RESPONSIBILITY FOR DAMAGES TO THINGS OR PEOPLE DERIVING FROM INCORRECT INSTALLATION OR IMPROPER, ERRONEOUS OR**

**UNSUITABLE USE.**

**THE APPLIANCE MUST NOT BE USED BY PEOPLE (INCLUDING CHILDREN) WITH PHYSICAL, SENSORIAL OR MENTAL IMPAIRMENTS, OR BY PEOPLE WITHOUT THE NECESSARY EXPERIENCE OR KNOWLEDGE, UNLESS THEY ARE SUPERVISED OR INSTRUCTED IN THE USE OF THE APPLIANCE BY A PERSON RESPONSIBLE FOR THEIR SAFETY. CHILDREN MUST BE SUPERVISED TO ENSURE THAT THEY DO NOT PLAY WITH THE APPLIANCE.**

## Table of Contents

1. PRECAUTIONS
2. INSTRUCTIONS FOR RECYCLING -  
PROTECTION OF THE ENVIRONMENT
3. SAFETY INSTRUCTIONS
4. APPLIANCE DESCRIPTION
5. BEFORE YOU BEGIN
6. CONTROL PANEL
7. USING YOUR WARMING DRAWER
8. USING YOUR WARMING DRAWER
9. TROUBLESHOOTING
10. APPLIANCE INSTALLATION



**CONSUMER INSTRUCTIONS:** Includes recommendations for use, description of commands and correct procedures for the care and clearing of the appliance.



**INSTALLATION INSTRUCTIONS:** Use intended for qualified technicians.

## 1. PRECAUTIONS

This guide is an integral part of the appliance. Keep these instructions with you during use of your warming drawer. Read these instructions before installing and using the appliance. Installation should be performed by qualified personnel only, in conformity with current law. This appliance is intended for domestic use only in conformity with current EEC directives. The manufacturer will not be held liable in the event of a failure to follow THESE WARNINGS AND SAFETY INSTRUCTIONS. KEEP THESE INSTRUCTIONS WITH THE APPLIANCE. IF THE APPLIANCE SHOULD BE GIVEN TO ANOTHER PERSON MAKE SURE THESE INSTRUCTIONS ARE SUPPLIED WITH IT.

DO NOT USE THE APPLIANCE FOR HEATING PURPOSES. HIGHLY FLAMMABLE OBJECTS ARE AT RISK OF CATCHING FIRE IF PLACED IN THEIR PROXIMITY DUE TO ELEVATED TEMPERATURES.

DO NOT DISPOSE OF MATERIALS IN THE HOME. SORT THE VARIOUS MATERIALS BY CLASSIFICATION AND DISPOSE OF THEM PROPERLY.

THE LABELS DISPLAYED ON THIS APPLICATION ARE IN COMPLIANCE WITH THE DIRECTIVE 2002/96/CEE WASTE AND ELECTRICAL EQUIPMENT (WEE).

DO NOT OBSTRUCT THE OPENINGS AND FIXTURES INTENDED FOR HEAT CIRCULATION.

THE LABELS LOCATED ON THE APPLIANCE WHICH SHOW THE SERIAL NUMBER AND MODEL ARE FOUND ON THE HEATING BLOCK. NEVER REMOVE THE DATA LABEL.

**WARNING!** NEVER USE SHARP METAL OBJECTS OR ABRASIVE SCRUBBING PADS THAT COULD CAUSE DAMAGE TO THE SURFACE OF THE APPLIANCE. IF NECESSARY, USE STANDARD NON-ABRASIVE UTENSILS MADE OF WOOD OR PLASTIC.

## 2. INSTRUCTIONS FOR RECYCLING

### - PROTECTION OF THE ENVIRONMENT

Our products are made solely from non-polluting materials that do not harm the environment and are recyclable. We ask for your effort and collaboration in disposing of the packaging in a proper manner. Contact the product retailer or local organizations for further information on recycling. Dispose of the packaging properly. Parts of the package especially plastic, pose

a risk for children.

Your old appliance must also be disposed of properly.

**Important:** consign the appliance to the proper local organization authorized to collect broken appliances. Proper and intelligent disposal consists of recovering materials of value.

Remove the plugs or electrical cords of appliances that are no longer being used so that they no longer pose a threat to children.

## 3 SAFETY INSTRUCTIONS

The safety measures regarding the electric, gas and functions are found in the installation section. It is in your best interest and safety and also legally required that all electrical appliances be installed and repaired exclusively by qualified personnel in conformity with current standards. Our qualified personnel can guarantee that the works will be performed correctly. Gas and electric appliances must always be disconnected by experienced personnel. Before connecting appliances to electric circuits it is important to check and compare the connection data (voltage and frequency) shown on the label to the characteristics of the local electric line. It is essential that this data coincide in order to avoid damaging the appliances. For further help and assistance please contact your local electrician.

The electrical safety of the appliance is only guaranteed when attached to a ground conductor. The manufacturer will not be liable for damages caused by the absence or interruption of a ground conductor (i.e. electric shock).

The appliance must be installed and connected by a specialized electrician. If necessary, contact a local electrician who is familiar with local standards and regulations. The manufacturer will not be liable for damages caused by incorrect installation or installations not conforming to local and national laws.

**WARNING!** IN ORDER TO AVOID THE RISK OF ELECTRICAL SHOCK ONLY USE APPLIANCES THAT HAVE BEEN INSTALLED CORRECTLY.

**WARNING!** NEVER OPEN THE HOUSING OF THE APPLIANCE. IF YOU COME INTO CONTACT WITH PARTS UNDER PRESSURE OR IF THE ELECTRICAL AND/OR MECHANICAL STRUCTURES ARE MODIFIED, THIS COULD DAMAGE THE APPLIANCE AND CAUSE IT TO MALFUNCTION.

**WARNING!** DO NOT KEEP PLASTIC CONTAINERS OR ANY FLAMMABLE OBJECTS IN THE APPLIANCE. SUCH OBJECTS POSE A RISK OF CATCHING FIRE ONCE THE WARMING DRAWER IS TURNED ON.

**WARNING!** THIS APPLIANCE IS NOT SUITABLE FOR USE BY PEOPLE (CHILDREN INCLUDED) WITH PHYSICAL, SENSORIAL, AND/OR MENTAL IMPAIRMENTS. PEOPLE WITHOUT THE NECESSARY EXPERIENCE OR KNOWLEDGE OF THE APPLIANCE MUST BE SUPERVISED BY A RESPONSIBLE PERSON FOR THEIR OWN SAFETY. CHILDREN MUST BE SUPERVISED TO ENSURE THEY DO NOT PLAY WITH THE APPLIANCE.

**WARNING:** REMEMBER THAT CHILDREN'S SKIN IS MORE DELICATE AND SENSITIVE TO HIGH TEMPERATURES. KEEP APPLIANCE AWAY FROM CHILDREN. APPLIANCE MAY OVERHEAT IF USED INCORRECTLY: RISK OF BURNS

**WARNING:** THE INSIDE OF THE APPLIANCE CAN REACH TEMPERATURES OF 75°C DEPENDING ON THE SELECTED TEMPERATURE AND THE TIME OF OPERATION. IF NECESSARY USE GLOVES TO REMOVE THINGS FROM THE DRAWER.

THIS APPLIANCE IS INTENDED FOR DOMESTIC USE ONLY! FOLLOW THESE INSTRUCTIONS TO AVOID DAMAGING THE APPLIANCE OR CREATING DANGEROUS SITUATIONS:

- Do not lean or sit on the warming drawer when opened, this could cause damage to the telescopic guide. The maximum carrying weight of the warming drawer is 10kg.

**CLEANING:**

- Never use a vacuum cleaner. The vacuum could create pressure on the components causing a short circuit. The vacuum may also damage the surface and the components of the appliance: damages for which the manufacturer will not be liable.

- For cleaning the appliance we recommend following the suggestions listed under "Cleaning and Maintenance" of the manual.

**REPAIRS:**

- **ATTENTION!** Maintenance work and/or repairs must be performed exclusively by specialized personnel. Incorrect installation and maintenance can cause personal injury to the consumer for which the manufacturer will not be liable.

- **ATTENTION!** During the warranty period, the appliance may only be serviced by technicians authorized by the manufacturer or the warranty will be void.

- **ATTENTION!** Before beginning maintenance, installation, or repair work disconnect the appliance from the electrical outlet.

The appliance is disconnected only if:

- The electrical fuse is disconnected.
- The cord of the appliance is disconnected from the electrical outlet – to disconnect the appliance from the outlet pull the cord away from the outlet, manually disconnect the cord. The manufacturer will not be liable for damage caused by a failure to follow current regulations or the use of non-original replacement parts.

## 4. INSTRUCTIONS FOR THE CONSUMER

### 4.0 OPENING OF THE DRAWER

To open the drawer press the front of the drawer



(fig. A)



(fig. B),

Pull the drawer



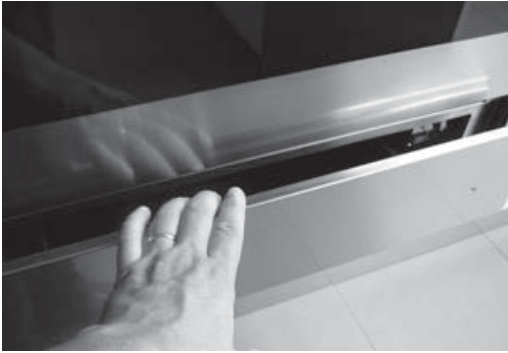

(fig. C)

towards you until it is opened completely.

#### 4.1 CLOSING THE DRAWER

To close the drawer, gently push the drawer back, pushing the front until it has completely gone back.

**4.2** The appliance is equipped with a hot air ventilating system. A fan distributes in an optimal way towards the internal space of the warming drawer.

The thermostat allows the user to control and set the appliance at the desired temperature.

The circulation of the air heats the drawer in a rapid and uniform way.

With the protective measures in place it is not possible to accidentally touch the heating element or the fan.

### 5. BEFORE YOU BEGIN



Do not leave parts of the packaging in the home. Separate the remaining packaging materials by category and deliver them to your nearest recycling center.

Before using the appliance for the first time, gently clean it with a moist cloth and dry it completely as described under "Cleaning and Maintenance".

Heat the warming drawer for at least two hours. Once heated, set the temperature to 75 °C. Be sure that the kitchen is kept well ventilated during the heating period.

The metal parts have been specially treated with a protective coating that can sometimes cause odors the first time the drawer is heated. These odors will quickly dissipate and should not be considered a defect of the appliance.

## 6. CONTROL PANEL

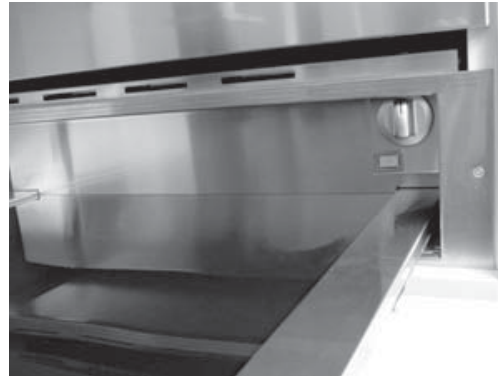

## 7. USING YOUR WARMING DRAWER

### 7.1 Operation

Open the drawer. Turn the knob in order to set the desired temperature and then press the red button.

A red light will turn on and will remain on throughout use.

To turn off the appliance, turn the knob to the 0 position and then press the button. The red light will turn off.

### 7.2 Heating Time

Different factors influence the time in which it takes to heat up:

- Thickness and material of the crockery;
- Amount of crockery;
- The arrangement of the loaded drawer;
- The desired temperate set.

So, there is no general rule. To set the temperature above 60°C in order to have a stable temperature, follow these suggestions:

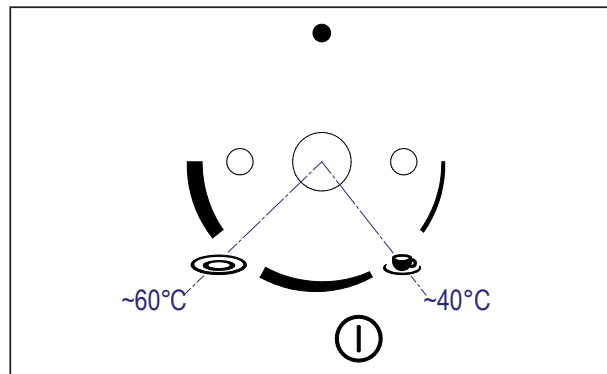

DISHES	TIME (MIN)
DISHES FOR 6 PERSONS	30-35

You can also use your own experience in determining the optimal temperature setting for your needs.

## 8 CLEANING AND MAINTENANCE

Generally speaking, cleaning is the only form of maintenance necessary.

**Attention!** Before you begin cleaning, disconnect the appliance from the outlet. Disconnect the cord from the outlet and turn off the appliance.

**Warning!** Do not use harsh detergents or abrasive products and/or scrubbing pads and sponges and sharp objects as they can stain and damage the appearance of the appliance.

**Warning!** Never use a vacuum cleaner on the internal parts of the appliance.

### 8.1 Front and Panel Commands

The use of a moist cloth is sufficient when cleaning the appliance. In the event the appliance requires further cleaning, add drops of detergent in the water. Dry the appliance with a dry cloth. The steel front of the appliance can be cleaned with products specifically designed for steel. Such products prevent the formation of dirt on the surface of the drawer. Apply a minimal amount of the product on a soft and apply it to the surface of the appliance.

### 8.2 Inside Space

To clean the inside space use a moist cloth. In the event the appliance requires further cleaning add drops of detergent to the water. Dry the surface with a dry cloth. Make sure to avoid water draining into the ventilation holes. Only use the appliance after the drawers are dry completely.

## 9 TROUBLESHOOTING

**ATTENTION!** Repairs must only be performed by specialized and qualified personnel. Any repair work not performed by professional personnel may cause damage to the appliance for which the manufacturer will not be liable.

The following problems can be fixed by the consumer without the assistance of the Service Department.

The drawer is not hot enough. Make sure that:

- The appliance is turned on;
- The correct temperature has been set;
- The opening of the ventilation fan is not blocked by plates or other large obstructions;
- The drawers have had sufficient time to heat up.

The drawer is not hot at all. Make sure that:

- You hear the fan running;
- If the fan is turned on this means that the heating system is working;
- If the fan does not work this means it is defective;
- The circuit fuse is blown.

## 10 APPLIANCE INSTALLATION

### 10.1 Before you begin installation

Make sure that the voltage shown on the appliance label corresponds to that of your electrical system.

Open the drawer and remove all accessories and packing materials.

**Attention!** The front of the drawer may be covered with a protective coating over it. Carefully remove the coating before using the appliance. Start by removing the protective film from the bottom. Make sure that the drawer is not damaged. Be certain that the drawer closes properly. In case of damage, contact the Service Department.

The warming drawer can only be attached and installed with the tools provided by the appliance manufacturer. The manufacturer does not guarantee the operation of the appliance if materials from a different manufacturer have been used. The manufacturer is not responsible for damage caused by improper use.

### 10.2 Proceed

Before you begin assembling the drawers of the appliance, make sure there is enough room to fit the drawer and the appliance.

The precise dimensions for the installment are indicated in mm. Follow these guidelines for assembly:

- Position the drawer so that it is directly centered
- Be certain that the frame is perfectly perpendicular
- Open the drawer and fix the structure to the wall with the two screws already in place

### 10.3 Electrical Installation

The electrical connection must be made by a qualified electrician conforming to current regulations.

**WARMING DRAWER WD14010 DIMENSION DIAGRAM 560 X 595 FOR 450 OVENS**

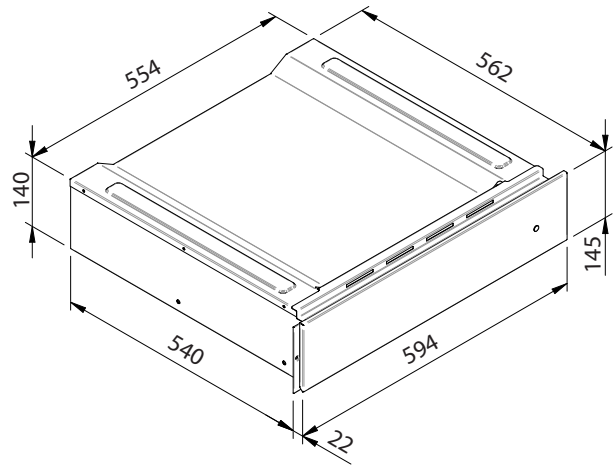
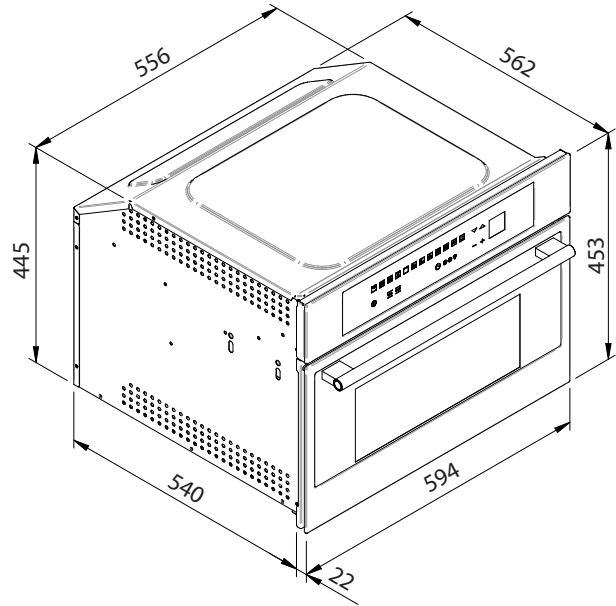
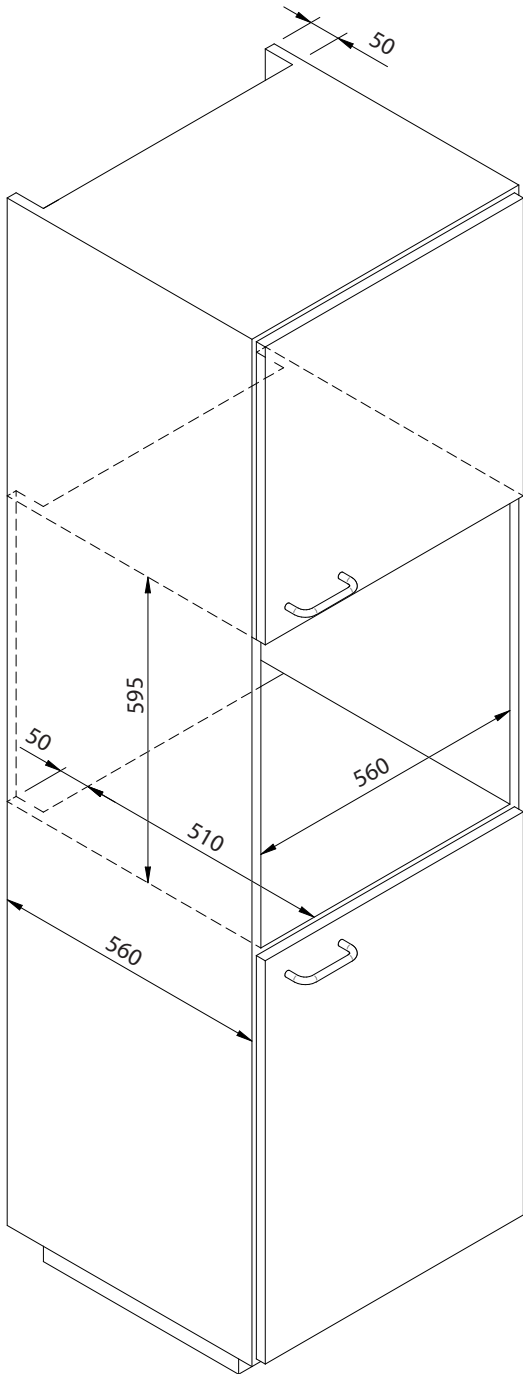

# WARMING DRAWER WD27010 DIMENSION DIAGRAM 560 X 720 FOR 450 OVENS

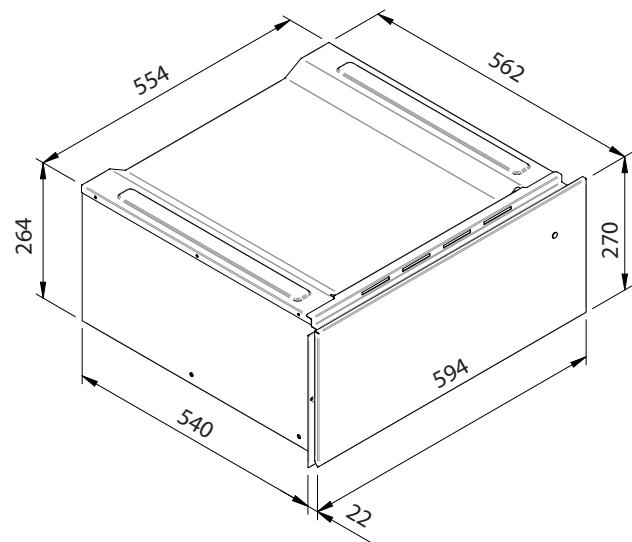
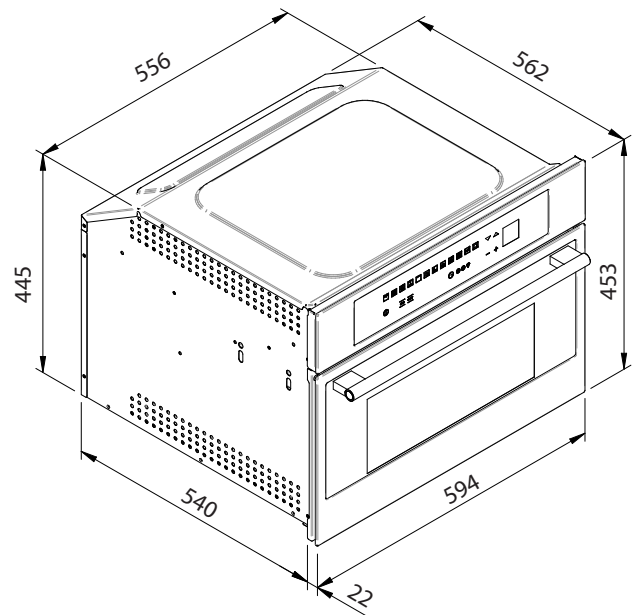
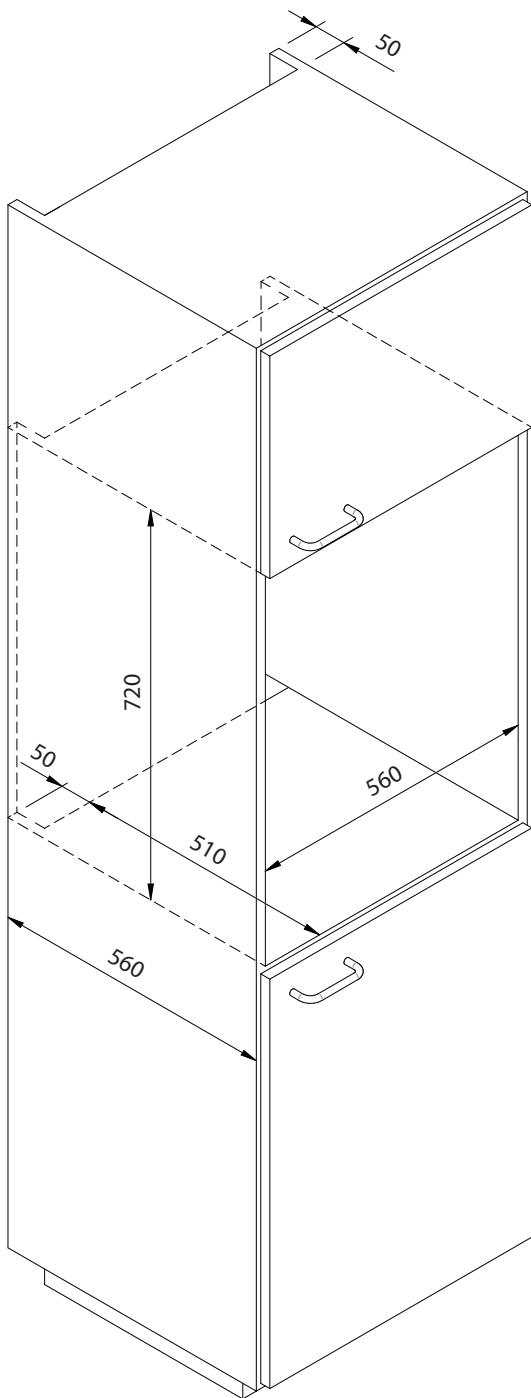

### Electrical connections

Before connecting the oven to the mains power supply, make sure that: - The supply voltage corresponds to the specifications on the data plate on the front of the oven. - The mains supply has an efficient earth (ground) connection complying with all applicable laws and regulations. Correct earthing (grounding) is a legal requirement. The power cable should never reach a temperature 50° C above ambient temperature at any point along its length. If a fixed appliance is not provided with a power cable and plug, or some other device permitting it to be disconnected from the mains electricity supply, with a gap between the contacts big enough to guarantee class III overvoltage protection, then such a device must be fitted to the power supply in compliance with the regulations governing electrical installations. The socket or switch must be easily reachable with the oven fully installed.

CABLE TYPES AND MINIMAL DIAMETERS	
	SASO
H05RR-F 3x0,75 mm <sup>2</sup>	H05RR-F 3x1,5 mm <sup>2</sup>
H05VV-F 3x0,75 mm <sup>2</sup>	H05VV-F 3x1,5 mm <sup>2</sup>
H05RN-F 3x0,75 mm <sup>2</sup>	H05RN-F 3x1,5 mm <sup>2</sup>
H05V2V2-F 3x0,75 mm <sup>2</sup>	H05V2V2-F 3x1,5 mm <sup>2</sup>

**WARNING!** Before connecting the warming drawer to the electrical circuit, verify that the voltage and the frequency correspond to those indicated on the label located inside the heating block, which should be kept along with this manual.

The electrical attachment must be made using bipolar switch capable of powering the appliance and that has a gap of 3 mm (minimum) to guarantee disconnection in case of emergency or when cleaning the warming drawer.

Connect the appliance to the ground circuit to conform to safety regulations regarding electrical systems.

**ATTENTION!** THE WARMING DRAWER MUST BE CONNECTED TO THE GROUND CIRCUIT.

In the event of the failure of the cable supplied with the warming drawer, replace it with an original replacement part provided by the Service Department.

The manufacturer and retailers will not be liable for property damage and personal injury caused by a failure to follow the instructions provided in this manual.

# KLEENMAID WARRANTY TERMS AND CONDITIONS

1. Compass Capital Services Pty Ltd ABN 96 138 214 525 trading as Kleenmaid will provide parts and labour to you the customer as set out herein.
2. Kleenmaid's Products come with guarantees that cannot be excluded under the Australian Consumer Law. You are entitled to a replacement or refund for a major failure and for compensation for any other reasonably foreseeable loss or damage. You are also entitled to have the goods repaired or replaced if the goods fail to be of acceptable quality and the failure does not amount to a major failure.
3. The benefits given to you under this Kleenmaid Warranty are in addition to other rights and remedies to which you may be entitled under the Australian Consumer Law in relation to the Product to which this Kleenmaid Warranty relates. Subject to the conditions below, the Product is warranted by Kleenmaid and/or its agents to be free from defects in materials and workmanship for the Warranty Period for normal Domestic Use.
4. Product Identification: -
  - a. Kleenmaid reserves the right to reject claims for any services or work where you cannot produce for verification the serial number and a proof of purchase for the Product (including but not limited to the original invoice).
  - b. This Kleenmaid Warranty will be voided if the serial number for the Product cannot be verified. This is not intended to exclude, restrict or modify any right or remedy to which you may otherwise be entitled under the consumer guarantee provisions of the Australian Consumer Law.
  - c. In the event that a request for repair is made against this Kleenmaid Warranty where the serial number for the Product cannot be verified or you cannot produce for verification a proof of purchase for the Product (including but not limited to the original invoice), the repairer will not carry out any repairs on the Product and you will be charged a service call-out fee.
5. What is covered by this Kleenmaid Warranty: -
  - a. The Product is covered for faulty workmanship or parts that have failed under normal Domestic Use.
  - b. Kleenmaid and/or its agents will determine by objective testing if there are any defects in the Product and/or faulty workmanship.
  - c. This Kleenmaid Warranty is only applicable if repairs on Products are carried out within Mainland Australia.
  - d. This Kleenmaid Warranty: -
    - i. covers a Product purchased as new, manufactured for use in Mainland Australia;
    - ii. commences from the date of delivery of the Product;
    - iii. provides for the labour and replacement parts necessary to maintain the Product in good operating condition as specified in this Kleenmaid Warranty, however, if repair is needed because of Product failure during normal Domestic Use, Kleenmaid has the option to repair or replace the defective Product or part of the Product with a product or part of like kind and quality. A replacement part may be new or reconditioned of like kind and quality and may cost less than the original Product purchased and no charges or refunds will be made based on the replacement product or part cost difference; and
    - iv. is only applicable when the Product is used and operated in accordance with the Manufacturer's instructions.
6. What is not Covered by this Kleenmaid Warranty (excluded):-
  - a. any damage or failure to or of the Product or part of the Product:
    - i. due to the Product being inadequately serviced to manufacturer's recommendations;
    - ii. resulting from environmental conditions including and not limited to dirt, dust, rodents, insects, rust, corrosion, salt built-up, of or in any part of the Product;
    - iii. resulting from excessive use but fair wear and tear is excepted;
    - iv. resulting from poor installation including and not limited to positioning and externally fitted equipment such as plumbing and drainage, cabling, antennae or due to incompatibility of connected equipment;
    - v. caused by overheating as a result of sitting or positioning of the Product, where there is no provision for adequate ventilation or adequate protection from excessive dust;
    - vi. if the Product has been dismantled, repaired or serviced by any person other than someone authorised by Kleenmaid or its agents or representatives;
    - vii. caused by power surges or spikes, including and not limited to, mains power and telecommunications connections, or to other unspecified sources, incorrect power current, voltage fluctuation, amperage fluctuation, rust or corrosion;
    - viii. if the Product is dropped, collision of the Product with another object, use for which the Product is not designed, damage to the Product caused by your own negligence, accidental or deliberate misuse of the Product by you, theft, abuse, vandalism, flood, fire, earthquake, electrical storms or any other act of God or any war related events; or
    - ix. due to the introduction of abnormal heat loads to the Product;
  - b. costs of attendance and testing where no fault or defect covered by the terms of this Kleenmaid Warranty is identified in the Product;
  - c. initial setup and installation of the Product;
  - d. normal maintenance costs and costs incurred through the installation of items listed as requiring periodic replacement;
  - e. Products with removed or altered serial numbers;
  - f. consumables such as but not limited to bulbs/globes, glass, seals, filters, batteries and remote controls;
  - g. removal and reinstallation of an internal component not performed by an authorised Kleenmaid agent or representative or authorised service centre;

- h. cosmetic or structural items; or
  - i. any failures due to interference from or with other products and/or sources.
7. This Kleenmaid Warranty ceases if: -
    - a. the Product ceases to carry the original manufacturer's serial number or is sold at an auction;
    - b. the Product is rented;
    - c. damage to the Product has occurred as listed in point 7a; or
    - d. there is failure to pay monies owing on invoices as a result of non-warranty work been carried out at the request of the end user as per point 16 below.
  8. Neither Kleenmaid nor its representatives provide loan equipment under the terms of this Kleenmaid Warranty.
  9. Any unauthorised access to the internal hardware of the Product will void this Kleenmaid Warranty.
  10. Repair Notice: Products presented for repair may be replaced by refurbished Products of the same type rather than being repaired. Refurbished parts may be used to repair the Products.
  11. Replacement items are "like for like" and is not "new for old" and does not indicate in any way that a faulty Product will be replaced with a new part or unit. "Like for like" may either be a quality checked, refurbished or reconditioned unit of the same or later batch of model/size/specifications
  12. The cost of making a claim under this Kleenmaid Warranty is not covered by Kleenmaid, including any costs of transportation or travel expenses between your home and your nearest authorised service agent.
  13. Kleenmaid accepts no liability for items that are lost, damaged, or stolen as a result of freight, transport or storage. If you are required to transport the Product to an authorised service centre, you must ensure that it is securely packed and insured.
  14. On Public Holidays or other periods when regular business and wholesale operations are temporarily ceased, repairer availability and warranty response times may extend beyond the standard response times due to the unavailability of repairers and parts.
  15. For any repair performed on a Product under this Kleenmaid Warranty where no fault can be found, or the item is deemed by Kleenmaid or an authorised agent, to be not faulty under this Kleenmaid Warranty, or the repair or fault is not covered under this Kleenmaid Warranty, a 'No Fault Found' fee is payable by you. Kleenmaid will advise you of this cost and seek your agreement to pay such costs before commencing such repairs.
  16. Any repairs or services required that are outside the terms and conditions of this Kleenmaid Warranty can be carried out at your request at your cost (including where the Product has not been installed or set up correctly). Kleenmaid will always advise you of this cost and seek your agreement to pay such costs before commencing such repairs. A credit card may be required prior to the commencement of such services.
  17. Extra charges will be payable by the customer should the Product not be readily accessible without special equipment, such as but not limited to cranes and lifts or should the Product be installed in a position that service access is blocked and/or repair work is not possible without uninstalling the Product to gain access.
  18. You, the customer, may be entitled to purchase an extended warranty in respect of the Product. Any extended warranty will not be issued by Kleenmaid but by a third party. Any extended warranty services will be provided directly by the third party as principal and not as agent for Kleenmaid, under their extended warranty terms and conditions and not under this Kleenmaid Warranty.
  19. To make a claim under this Kleenmaid Warranty, please have your proof of purchase and the serial number of the Product ready and call (02) 9310 1207 during business hours.
  20. This Kleenmaid Warranty is given by:
    - Name: Compass Capital Services Pty Ltd ABN 96 138 214 525 trading as Kleenmaid
    - Business address: Level 2, Suite 3, 204 Botany Rd, Alexandria NSW Australia 2015
    - Telephone: (02) 9310 1207
  21. Definitions:
    - a. **Australian Consumer Law** means the *Competition and Consumer Act 2010* (Cth).
    - b. **Domestic Use** means use of the Product for personal, domestic or household purposes.
    - c. **Kleenmaid** means Compass Capital Services Pty Ltd ABN 96 138 214 525 trading as Kleenmaid.
    - d. **Mainland Australia** means the following States and Territories of Australia: New South Wales, Victoria, South Australia, Western Australia, Queensland, Tasmania, Northern Territory, Australian Capital Territory.
    - e. **Product** means the appliance sold by Kleenmaid to you as evidenced by the original purchase invoice.
    - f. **Warranty Period** means the period of 36 months for domestic use, 12 months for non-domestic use or such alternative period as may be specified.

**UPDATE NOTICE:** This Kleenmaid Warranty is current as at 7 March 2017 but is subject to variation from time to time. For the latest version of the Kleenmaid Warranty, please see our website <http://www.kleenmaid-appliances.com.au/support/your-kleenmaid-warranty> or phone us on (02) 9310 1207.

## Other products available in the Kleenmaid range of appliances

---

- | Washing machines
- | Clothes dryers
- | Dishwashers
- | Ovens
- | Cooktops
- | Steam ovens
- | Microwave ovens
- | Built in espresso  
coffee machines
- | Rangehoods
- | Freestanding ovens

Compass Capital Services Pty Limited  
trading as Kleenmaid  
ABN 96138214525

Level 2, 204 Botany Road  
Alexandria NSW 2015

E: [support@kleenmaid.com.au](mailto:support@kleenmaid.com.au)  
[www.kleenmaid.com.au](http://www.kleenmaid.com.au)

